

GRIT TREATMENT EQUIPMENT + KoNUX.PLUS GRIT SEPARATORS

KoNUX.PLUS Grit Separator is a compact unit which is combining grit classifying and grit dewatering processes in a single tank with a small footprint. Optimum separation and dewatering of grit to reduce the storage and disposal costs is obtained effectively.

KNX+ is consisting of an inlet structure, a conical tank where grit is settled and separated by an inclined spiral classifier. The special developed helical inlet structure guides the flow pattern to rotate and create a vortex to achieve a highly efficient separation performance.

As grit and organics content are denser than water, vortex flow pattern leads these heavier particles towards the side walls and to bottom of the conical tank and ensure continuous separation efficiency. Overflowed liquid is discharged through the outlet connection located at the upper side of the tank.

Discharge and simultaneous static dewatering of the separated grit is completed by means of a robust grit classifying screw in the inclined trough. Separated and washed grit is slowly transported upwards in an inclined trough to be dewatered and discharged.

KNX+C has three different standard design sizes to accommodate different capacity requirements in a cost efficient and reliable way.

	KNX+C16	KNX+C18	KNX+C24
Inlet Capacity (m ³ /h)	28	57	90
Grit Discharge (m ³ /h)	0,3	0,5	1,0

KNX+W has an integrated washing unit. After sedimentation, solids are washed out by service water and organic components are separated from the inorganics due to their differences in density. Washing is supported by a slow rotating stirrer.

KNX+W has three different standard design sizes to accommodate different capacity requirements in a cost efficient and reliable way.

	KNX+W18	KNX+W24	KNX+W32
Inlet Capacity (m ³ /h)	28	57	90
Grit Discharge (m ³ /h)	0,3	0,5	1,0

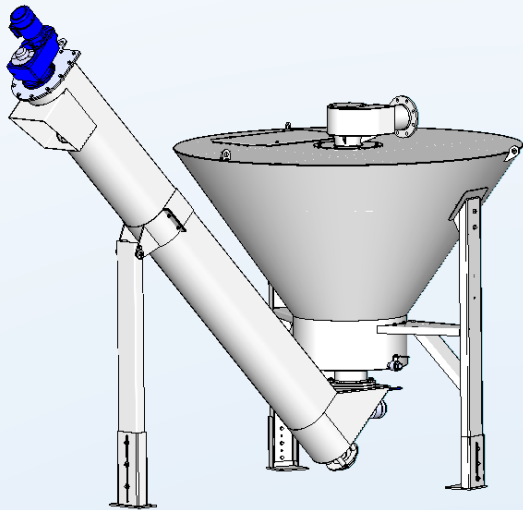

KNX+C Grit Classifier

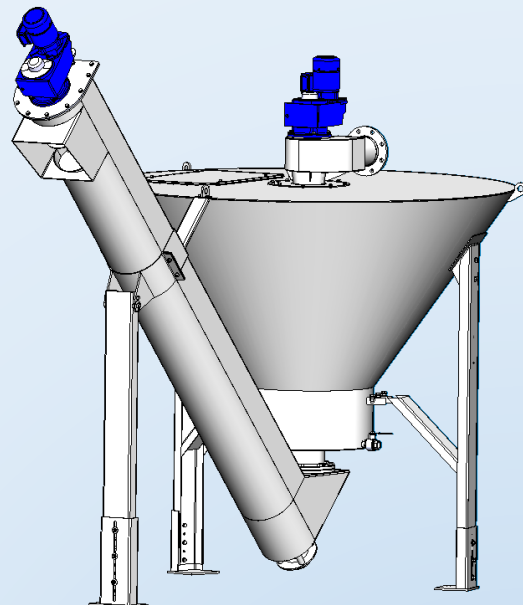

KNX+W Grit Washer